

Composite Steel and Concrete

Clinton O. Rex, P.E., PhD

*Originally developed by
James Robert Harris, P.E., PhD, and Frederick R. Rutz, P.E., PhD*

The 2009 *NEHRP Recommended Provisions* for the design of a composite building using a “Composite Partially Restrained Moment Frame” (C-PRMF) as the lateral force-resisting system is illustrated in this chapter by means of an example design. The C-PRMF lateral force-resisting system is recognized in *Standard* Section 12.2 and in AISC 341 Part II Section 8, and it is an appropriate choice for buildings in low to moderate Seismic Design Categories (SDC A to D). There are other composite lateral force-resisting systems recognized by the *Standard* and AISC 341; however, the C-PRMF is the only one illustrated in this set of design examples.

The design of a C-PRMF is different from the design of a more traditional steel moment frame in three important ways. First, the design of a Partially Restrained Composite Connection (PRCC) differs in that the connection itself is not designed to be stronger than the beam it is connecting. Consequently, the lateral system typically will hinge within the connections and not within the associated beams or columns. Second, because the connections are neither simple nor rigid, their stiffness must be accounted for in the frame analysis. Third, because the connections are weaker than fully restrained moment connections, the lateral force-resisting system requires more frames with more connections, resulting in a highly redundant system.

In addition to the 2009 *NEHRP Recommended Provisions* (referred to herein as the *Provisions*), the following documents are referenced throughout the example:

- | | |
|-------------|---|
| ACI 318 | American Concrete Institute. 2008. <i>Building Code Requirements for Structural Concrete</i> . |
| AISC 360 | American Institute of Steel Construction. 2005. <i>Specification for Structural Steel Buildings</i> . |
| AISC 341 | American Institute of Steel Construction. 2005. <i>Seismic Provisions for Structural Steel Buildings</i> , including Supplement No. 1. |
| AISC SDGS-8 | American Institute of Steel Construction. 1996. <i>Partially Restrained Composite Connections</i> , Steel Design Guide Series 8. Chicago: AISC. |
| ASCE TC | American Society of Civil Engineers Task Committee on Design Criteria for Composite Structures in Steel and Concrete. October 1998. “Design Guide for |

	Partially Restrained Composite Connections,” <i>Journal of Structural Engineering</i> 124(10).
RCSC	Research Council on Structural Connections. 2004. <i>Specification for Structural Joints Using ASTM A325 or A490 Bolts</i> .
AISC Manual	American Institute of Steel Construction. 2005. <i>Steel Construction Manual</i> . Thirteenth Edition.
AISC SDM	American Institute of Steel Construction. 2006. <i>Seismic Design Manual</i> . First Edition.
Arum (1996)	Arum, 12-5-1996. Design, Analysis, and Application of Bolted Semi-Rigid Connections for Moment Resisting Frames, MS Thesis, Lehigh University.

The short-form designations presented above for each citation are used throughout.

The PRCC used in the example has been subjected to extensive laboratory testing, resulting in the recommendations of AISC SDGS-8 and ASCE TC. ASCE TC is the latter of the two guidance documents and is referenced here more often; however, AISC SDGS-8 provides information not in ASCE TC, which is still pertinent to the design of this type of frame. While both of these documents provide guidance for design of PRCC, the method presented in this design example deviates from that guidance based on more recent code requirements for stability and on years of experience in designing C-PRMF systems.

The structure is analyzed using three-dimensional, static, nonlinear methods. The SAP 2000 analysis program, v. 14.0 (Computers and Structures, Inc., Berkeley, California) is used in the example.

The symbols used in this chapter are from Chapter 2 of the *Standard* or the above referenced documents, or are as defined in the text. U.S. Customary units are used.

9.1 BUILDING DESCRIPTION

The example building is a four-story steel framed medical office building located in Denver, Colorado (see Figures 9.1-1 through 9.1-3). The building is free of plan and vertical irregularities. Floor and roof slabs are 4.5-inch normal-weight reinforced concrete on 0.6-inch form deck (total slab depth of 4.5 inches.). Typically slabs are supported by open web steel joists which are supported by composite steel girders. Composite steel beams replace the joists at the spandrel condition to help control cladding deflections. The lateral load-resisting system is a C-PRMF in accordance with *Standard* Table 12.2-1 and AISC 341 Part II Section 8. The C-PRMF uses PRCCs at almost all beam-to-column connections. A conceptual detail of a PRCC is presented in Figure 9.1-4. The key advantage of this type of moment connection is that it requires no welding. The lack of field welding results in erection that is quicker and easier than that for more traditional moment connections with CJP welding and the associated inspections.

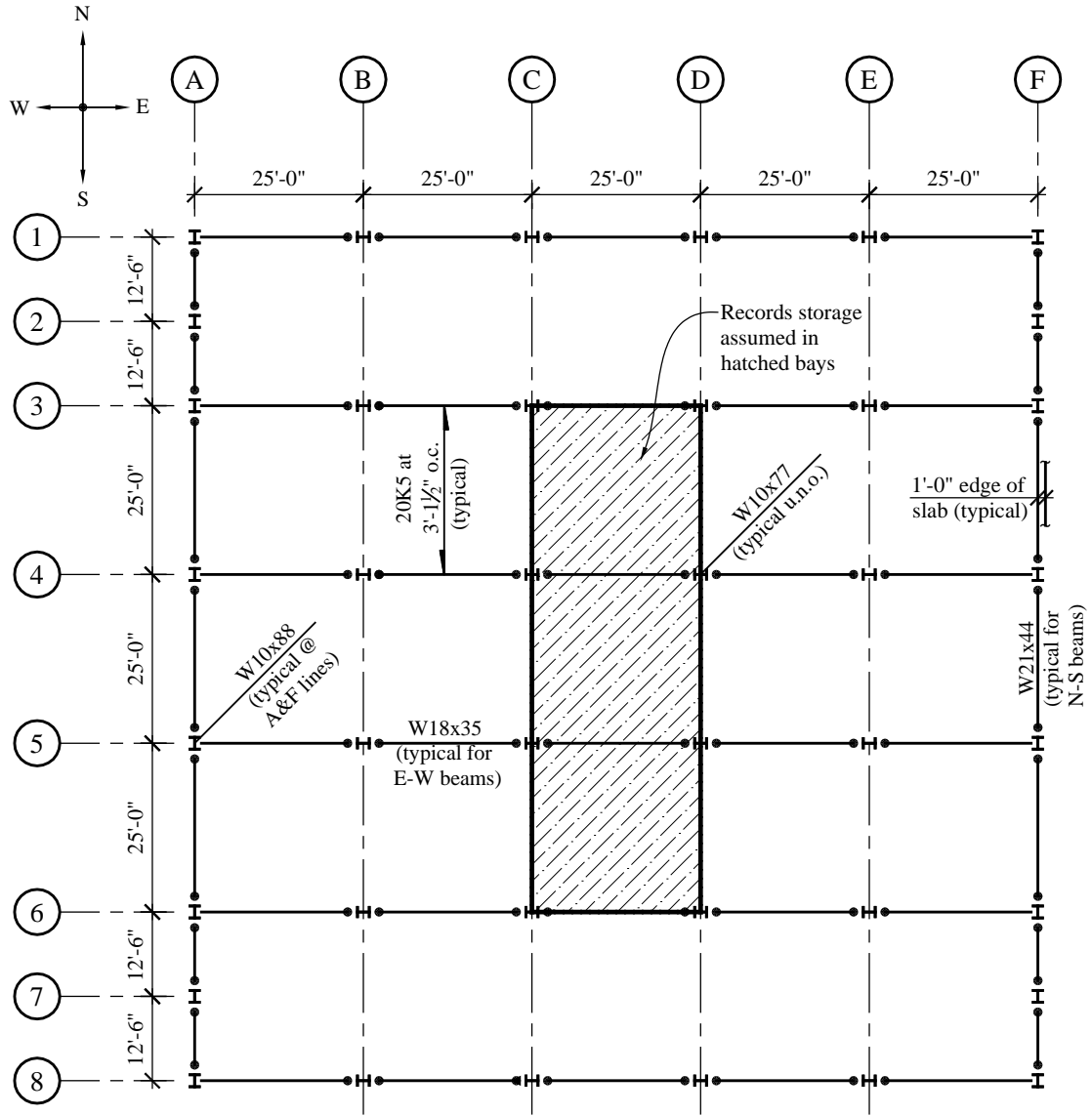

Figure 9.1-1 Typical floor and roof plan

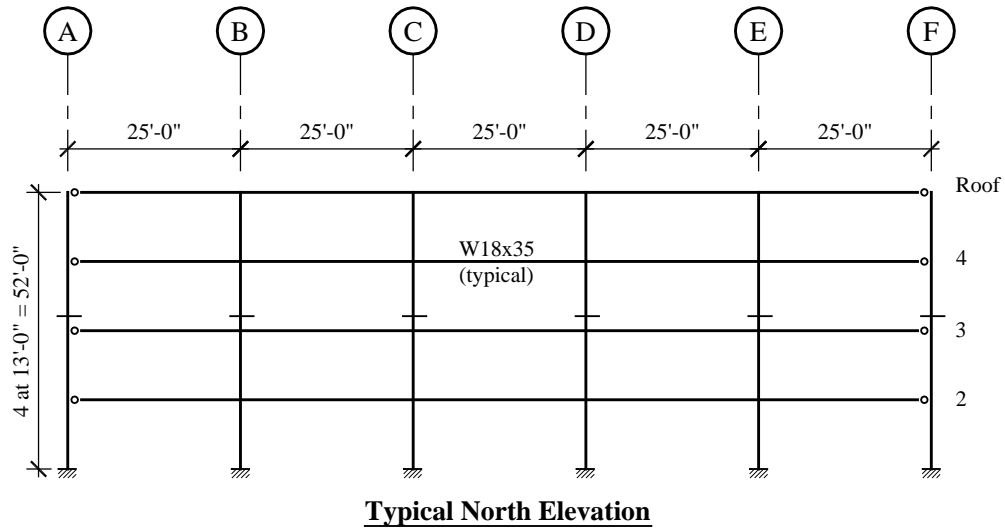

Figure 9.1-2 Building end elevation

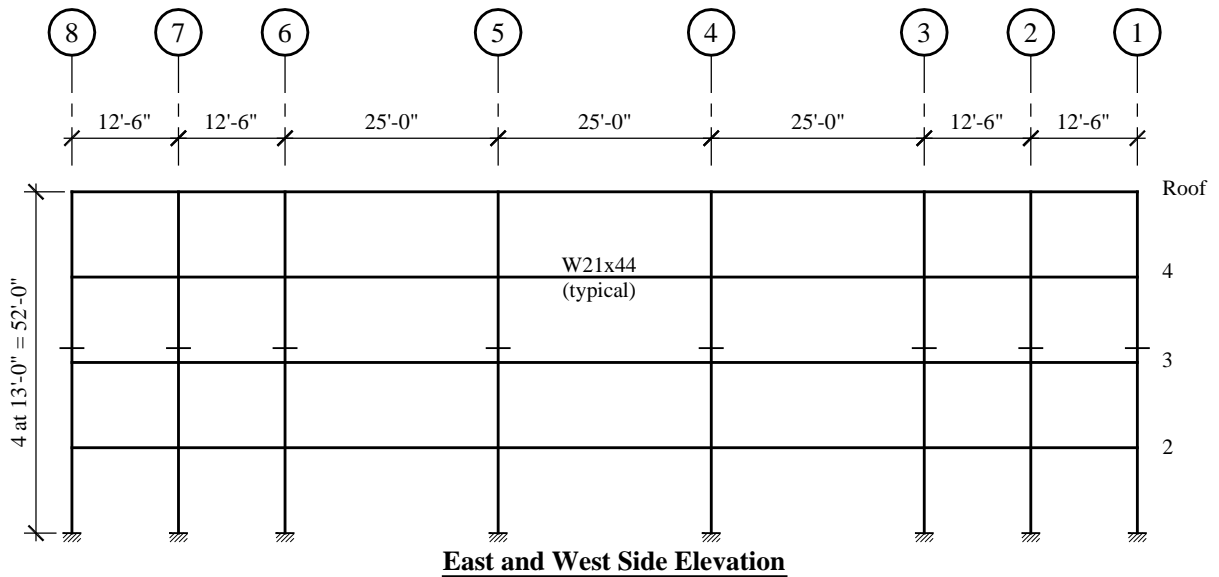

Figure 9.1-3 Building side elevation

The building is located in a relatively low seismic hazard region, but localized internal storage loading and Site Class E are used in this example to provide somewhat higher seismic design forces for purposes of illustration, and to push the example building into Seismic Design Category C.

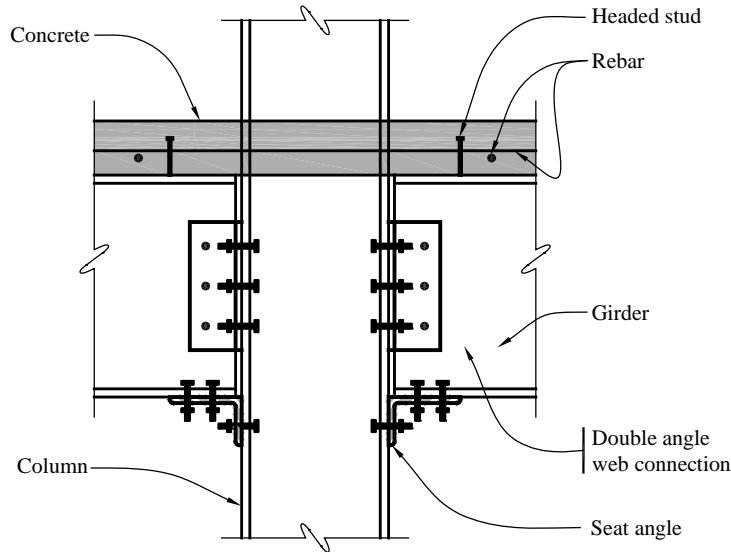

Figure 9.1-4 Conceptual partially restrained composite connection (PRCC)

There are no foundations designed in this example. For this location and system, the typical foundation would be a drilled pier and voided grade beam system, which would provide flexural restraint for the strong axis of the columns at their base (very similar to the foundation for a conventional steel moment frame). The main purpose here is to illustrate the procedures for the PRCCs. The floor and roof slabs serve as horizontal diaphragms distributing the seismic forces, and by inspection they are stiff enough to be considered as rigid.

The typical bay spacing is 25 feet. Architectural considerations allowed an extra column at the end bay of each side in the north-south direction, which is useful in what is the naturally weaker direction. The exterior frames in the north-south direction have moment-resisting connections at all columns. The frames in each bay in the east-west direction have moment-resisting connections at all columns except the end columns. Composite connections to the weak axis of the column are feasible, but they are not used for this design. The PRCC connection locations are illustrated in Figure 9.1-1.

Material properties in this example are as follows:

- Structural steel beams and columns (ASTM A992): $F_y = 50$ ksi
- Structural steel connection angles and plates (ASTM A36): $F_y = 36$ ksi
- Concrete slab (4.5 inches thick on form deck, normal weight): $f'_c = 3,000$ psi
- Steel reinforcing bars (ASTM A615): $F_y = 60$ ksi

9.2 PARTIALLY RESTRAINED COMPOSITE CONNECTIONS

9.2.1 Connection Details

The type of PRCC used for this example building consists of a reinforced composite slab, a double-angle bolted web connection, and a bolted seat angle. In real partially restrained building design, it is

advantageous to select and design the complete PRCC simply based on beam depth and element capacities. Generally it is impractical to “tune” connections to beam plastic moment capacities and/or lateral load demands. This allows the designer to develop an in-house suite of PRCC details and associated behavior curves for each nominal beam depth ahead of time. Slight adjustments can be made later to account for real versus nominal beam depth.

It is considered good practice (particularly for capacity-based seismic design) to provide substantial rotation capacity at connections while avoiding non-ductile failure modes. This requirement for ductile rotation capacity is expressed in AISC 341 Part II Section 8.4 as a requirement for interstory drift of 0.04 radians. Because much of the drift in a partially restrained building comes from connection rotation, this interstory drift requirement implies a connection rotation ductility requirement. In short, connections must be detailed to allow ductile failure modes to dominate over non-ductile failure modes.

Practical detailing is limited by commonly available components. For instance, the largest angle leg commonly available is 8 inches, which can reasonably accommodate four 1-inch-diameter bolts. As a result, the maximum shear that can be delivered from the beam flange to the seat angle is limited by shear in four A490-X bolts. Bolt shear failure is generally considered to be non-ductile, so the rest of the connection design and detailing aims to maximize moment capacity of the connection while avoiding this limit state.

The connection details chosen for this example are illustrated in Figures 9.2-1, 9.2-2, and 9.2-3.

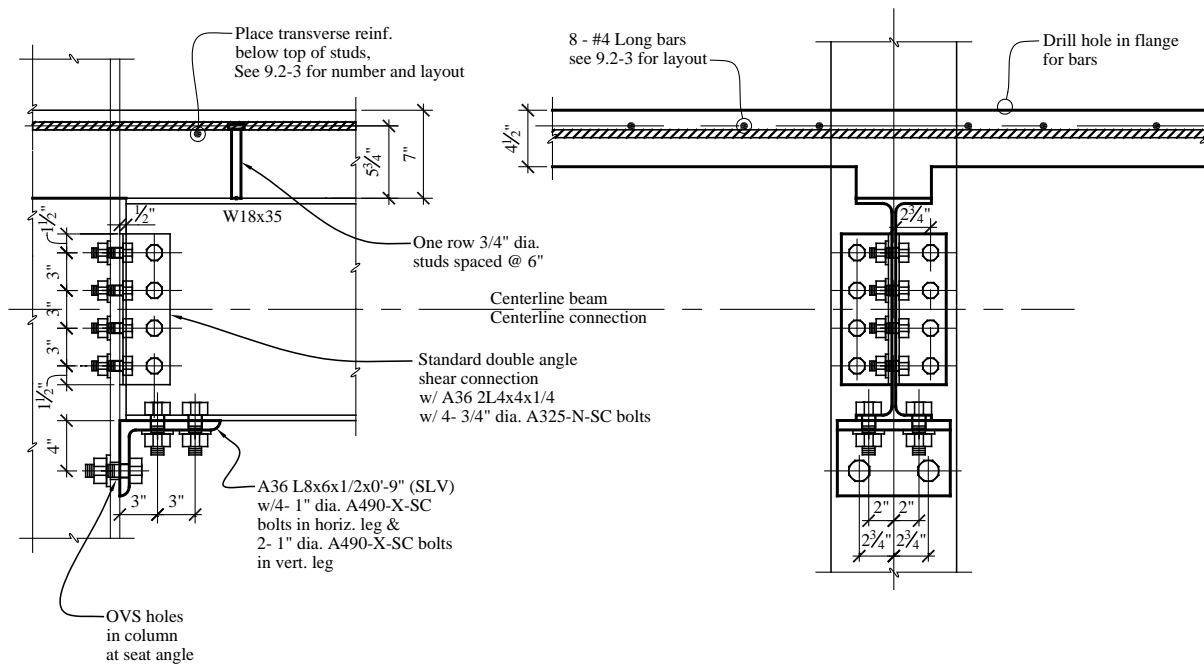

Figure 9.2-1 Typical interior W18x35 PRCC

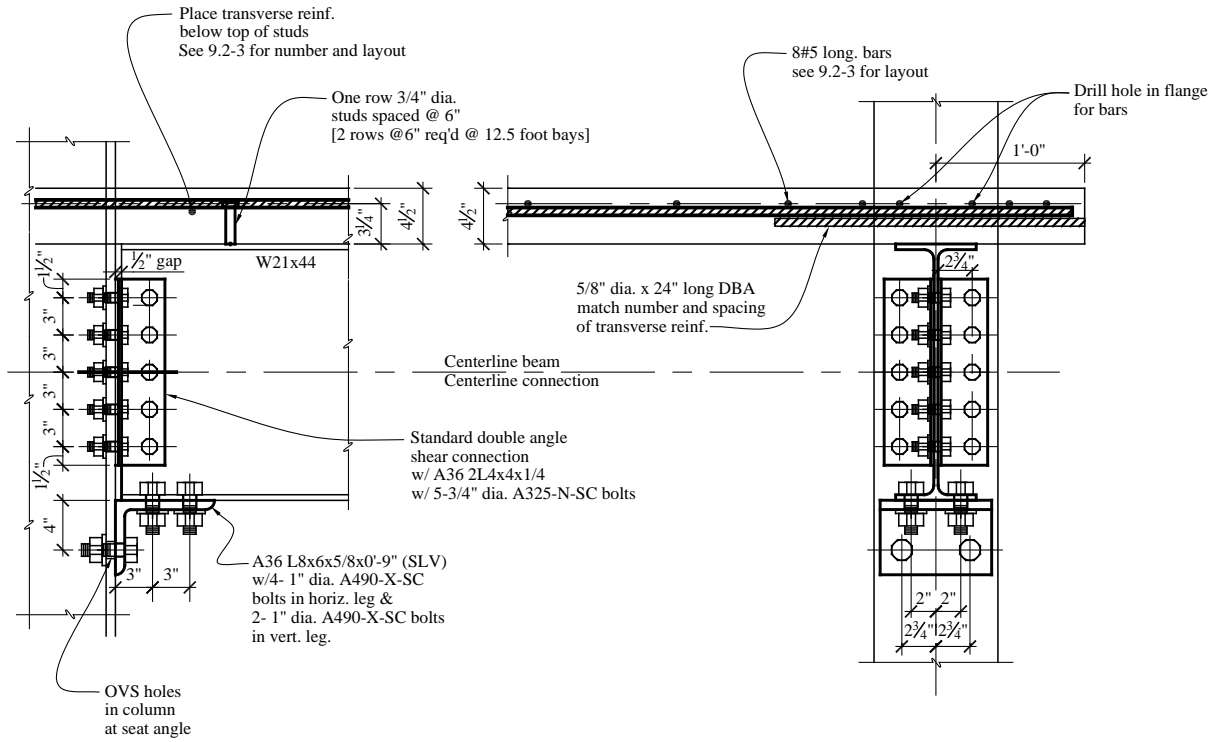

Figure 9.2-2 Typical spandrel W21x44 PRCC

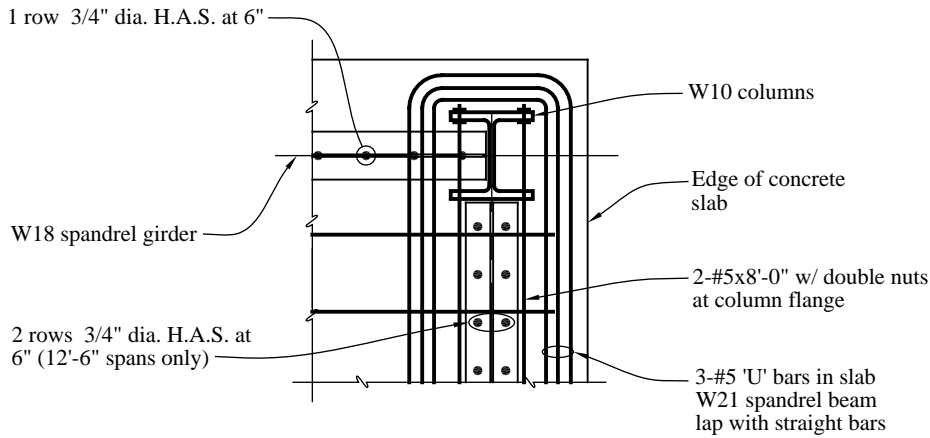

Figure 9.2-3 Typical corner PRCC

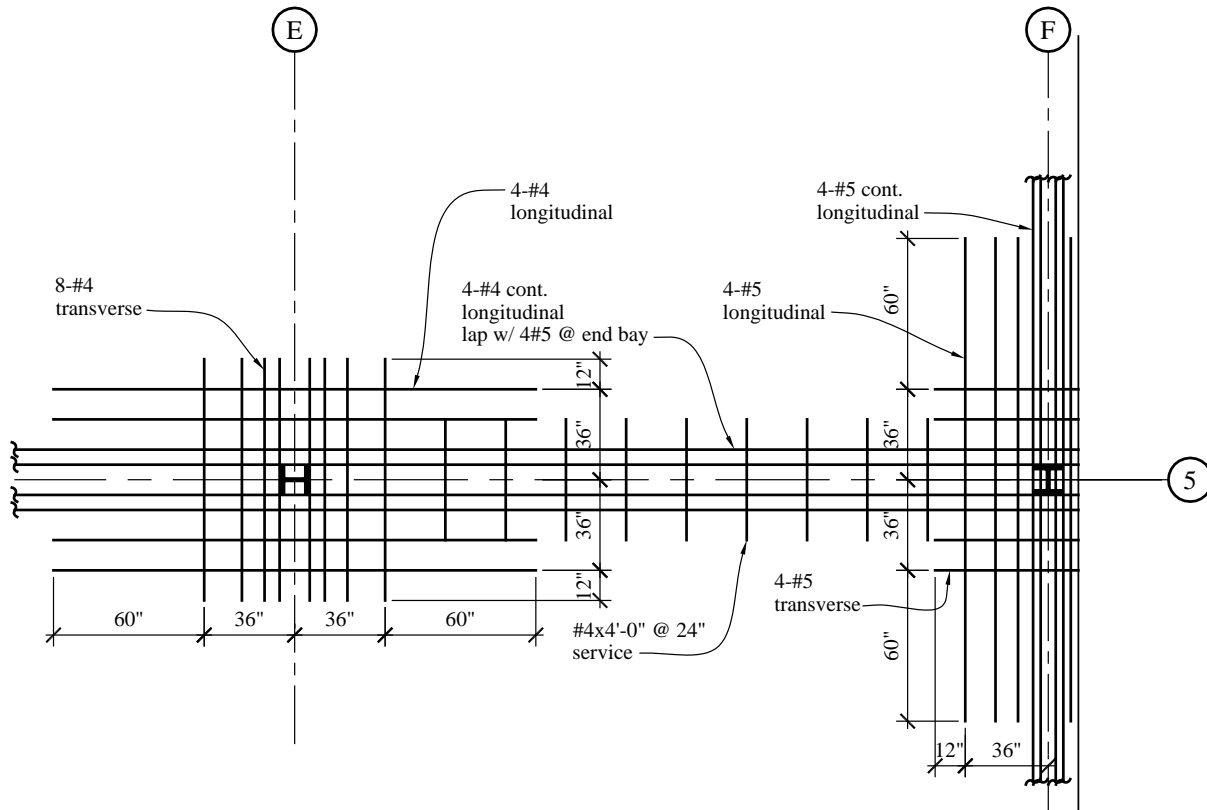

Figure 9.2-4 Typical PRCC reinforcing plan

9.2.2 Connection Moment-Rotation Curves

Two connection moment-rotation curves are required for the design of partially restrained buildings: the nominal moment-rotation curve and the modified moment-rotation curve.

The nominal moment-rotation curve, obtained from connection test data or from published moment-rotation prediction models, is used for service-level load design. For this example, the published moment-rotation prediction model given in ASCE TC is used to define the moment-rotation curve for the PRCC.

Negative moment-rotation behavior (slab in tension):

$$M_c^- = C_1 \left(1 - e^{-C_2 \theta} \right) + C_3 \theta \quad (\text{ASCE TC, Eq. 4})$$

Where:

$$C_1 = 0.18(4 \times A_{rb} F_{yrb} + 0.857 A_{sa} F_{ya})(d + Y_3), \text{ kip-in.}$$

$$C_2 = 0.775$$

$$C_3 = 0.007(A_{sa} + A_{wa}) F_{ya} (d + Y_3), \text{ kip-in.}$$

$$\theta = \text{connection rotation (mrad = radians} \times 1,000)$$

d = beam depth, in.

Y_3 = distance from top of beam to the centroid of the longitudinal slab reinforcement, in.

A_{rb} = area of longitudinal slab reinforcement, in²

A_{sa} = gross area of seat angle leg, in²

(For use in these equations, A_{sa} is limited to a maximum of $1.5A_{rb}$)

A_{wa} = gross area of double web angles for shear calculations, in²

(For use in these equations, A_{wa} is limited to a maximum of $2.0A_{sa}$)

F_{yrb} = yield stress of reinforcing, ksi

F_{ya} = yield stress of seat and web angles, ksi

Positive moment-rotation behavior (slab in compression):

$$M_c^+ = C_1(1 - e^{-C_2\theta}) + (C_3 + C_4)\theta \quad (\text{ASCE TC, Eq. 3})$$

Where:

$$C_1 = 0.2400[(0.48A_{wa}) + A_{sa}](d + Y_3)F_{ya}, \text{ kip-in.}$$

$$C_2 = 0.0210(d + Y_3/2)$$

$$C_3 = 0.0100(A_{wL} + A_L)(d + Y_3)F_{ya}, \text{ kip-in.}$$

$$C_4 = 0.0065 A_{wL}(d + Y_3)F_{ya}, \text{ kip-in.}$$

The modified moment-rotation curve is used for strength level load design. The Direct Analysis Method requires two modifications to the nominal moment-rotation curve: an elastic stiffness reduction and a strength reduction. AISC 360 Section 7.3(3) requires an elastic stiffness reduction of 0.8, which is accomplished by translating the connection rotation by an elastic stiffness reduction offset. This translation can be shown as follows:

$$\theta_{cDAM} = \theta_c + \frac{M_c}{4 \times K_{ci}}$$

Where:

M_c = connection moment from the nominal moment-rotation curve, kip-in.

K_{ci} = connection initial stiffness, kip-in./mrad; because the moment-rotation curve is nonlinear, it is necessary to define how the initial stiffness will be measured. For this example, the initial stiffness will be taken as the secant stiffness to the moment-rotation curve at $\theta = 2.5$ mrad as suggested in ASCE TC. Note that this will be different values for the positive and negative moment-rotation portions of the connection behavior.

$$K_{ci} = \frac{M_{c@2.5\text{ mrad}}}{2.5\text{ mrad}}$$

The second modification to the nominal moment-rotation curve is a strength reduction associated with ϕ . ASCE TC recommends using ϕ equal to 0.85. The associated connection strength is given by:

$$M_{cDAM} = 0.85 M_c$$

From these equations, curves for $M-\theta$ can be developed for a particular connection. The moment-rotation curves for the typical connections associated with the W18x35 girder and the W21x44 spandrel beam are presented in Figures 9.2-5 and 9.2-6, respectively.

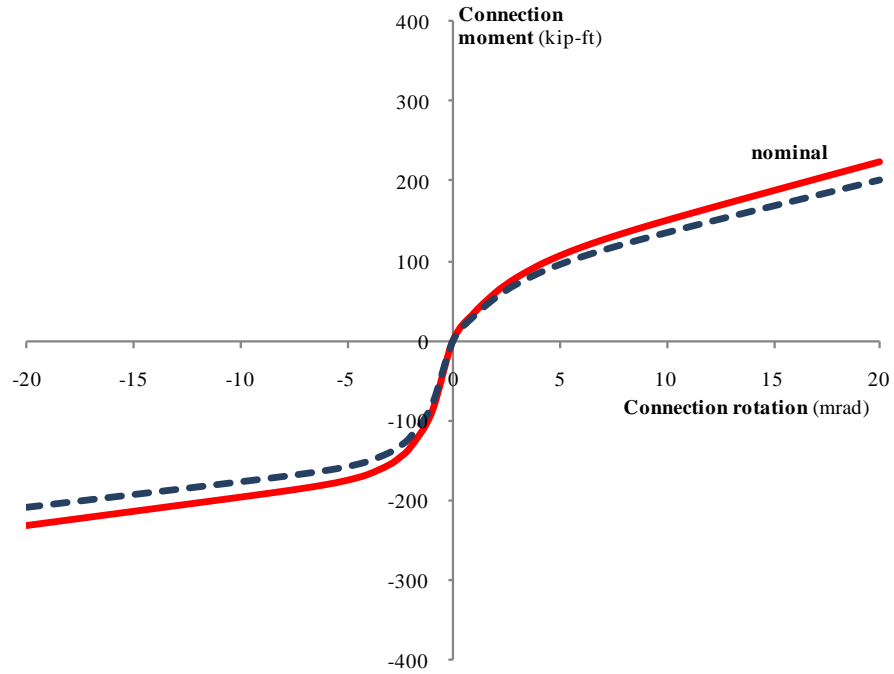

Figure 9.2-5 Typical interior W18x35 PRCC $M-\theta$ curves

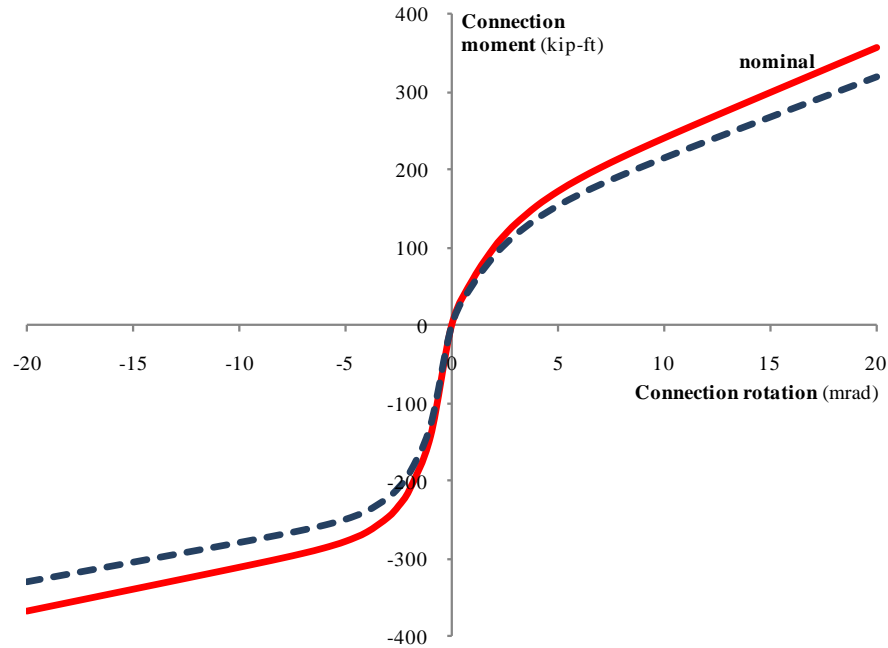

Figure 9.2-6 Typical spandrel W21x44 PRCC $M-\theta$ curves

Important key values from the above connection curves are summarized in Table 9.2-1 for reference in later parts of the example design.

Table 9.2-1 Key Connection Values From Moment-Rotation Curves

	W18x35 PRCC	W21x44 PRCC
K_{ci}^- (kip-in/rad)	704,497	1,115,253
K_{ci}^+ (kip-in/rad)	338,910	554,498
M_c^- @ 20 mrad (kip-ft)	232	367
M_c^+ @ 10 mrad (kip-ft)	151	240

These curves and the corresponding equations do not reproduce the results of any single test. Rather, they are averages fitted to real test data using numerical methods, and they smear out the slip of bolts into bearing. Articles in the *AISC Engineering Journal* (Vol. 24, No.2; Vol. 24, No.4; Vol. 27, No.1; Vol. 27, No. 2; and Vol. 31, No. 2) describe actual test results. Those tests demonstrate clearly the ability of the connection to satisfy the rotation requirements of AISC 341 Part II Section 8.4.

9.2.3 Connection Design

This section illustrates the detailed design decisions and checks associated with the typical W21x44 spandrel beam connection. A complete design would require similar checks for each different connection

type in the building. Design typically involves iteration on some of the chosen details until all the design checks are within acceptable limits.

9.2.3.1 Longitudinal Reinforcing Steel. The primary negative moment resistance derives from tensile yielding of slab reinforcing steel. Since ductile response of the connection requires that the reinforcing steel yield and elongate prior to failure of other connection components, providing too much reinforcing is not a good thing. The following recommendations are from ASCE TC.

A minimum of six bars (three bars each side of column), #6 or smaller, should be used (eight #5 bars have been used in this example). The bars should be distributed symmetrically within a total effective width of seven column flange widths (36 inches at each side of the column has been used in this example). For edge beams, the steel should be distributed as symmetrically as possible, with at least one-third (minimum three bars) of the total reinforcing on the exterior side of the column. Bars should extend a minimum of one-fourth of the beam length or 24 bar diameters past the assumed inflection point at each side of the column. For seismic design a minimum of 50 percent of the reinforcing steel should be detailed continuously. Continuous reinforcing should be spliced with a Class B tension lap splice, and minimum cover should be in accordance with ACI 318.

9.2.3.2 Transverse Reinforcing Steel. The purpose of the transverse reinforcing steel is to help promote the force transfer from the tension reinforcing to the column and to prevent potential shear splitting of the slab over the beams, thus allowing the beam studs to transfer the reinforcing tension force into the beam. ASCE TC recommends the following.

Provide transverse reinforcement, consistent with a strut-and-tie model as shown in Figure 9.2-7. In the limit (maximum), this amount will be equal to the longitudinal reinforcement. The transverse reinforcing should be placed below the top of the studs to prevent a cone-type failure over the studs. The transverse bars should extend at least 12 bar diameters or 12 inches, whichever is larger, on either side of the outside longitudinal bars.

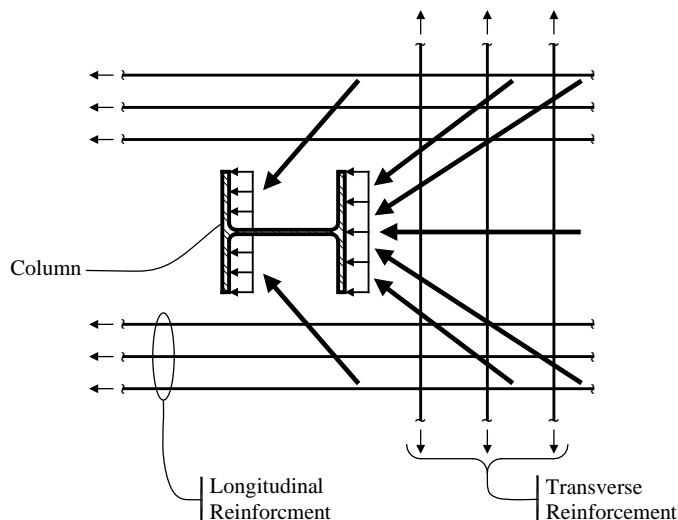

Figure 9.2-7 Force transfer mechanism from slab to column

Concrete bearing stresses on the column flange should be limited to $18f'_c$ per the ASCE TC recommendations. For the W21x44 PRCC, the sum of the positive and negative moment capacity is 607 kip-ft. The moment arm is approximately 22.95 inches ($20.7 + 4.5/2$). So the maximum possible transfer of force from the slab to the column, if each connection is at maximum and opposite strengths on each side of the column, is $607 \text{ ft-kip}/22.95 \text{ inches} = 317 \text{ kips}$. A W10x88 column has a 10.3-inch-wide flange. Assuming uniform bearing of the concrete on each flange, the bearing stress would be $317 \text{ kips} / 2 \text{ flanges} / 4.5\text{-inch-thick slab} / 10.3\text{-inch-wide flange} = 3.42 \text{ ksi}$, which is less than the recommended limit of $18f'_c$. It is also necessary to check this force against the flange local bending and web local yielding limit states given in Chapter J of AISC 360. It is important to have concrete filling the gap between column flanges; otherwise, the force must be transferred by a single column flange.

9.2.3.3 Connection Moment Capacity Limits. AISC 341 Part II Section 8.4 requires that the PRCC have a nominal strength that is at least equal to 50 percent of the nominal M_p for the connected beam ignoring composite action. ASCE TC recommends 75 percent as a good target, with 50 percent as a lower limit and 100 percent as an upper limit. ASCE TC also recommends using the moment capacity at 20 mrad for negative moment and 10 mrad for positive moment to determine the nominal connection moment capacity. From the W21x44 PRCC connection curve, the negative moment capacity at 20 mrad is 367 kip-ft and the positive moment capacity at 10 mrad is 240 kip-ft. With M_p of the beam being 398 kip-ft, the ratio of connection-to-beam moment capacity is 0.922 and 0.603 for negative and positive moments, respectively.

9.2.3.4 Seat Angle. The typical gage for the bolts attaching the seat angle to the column is 5.5 inches to allow sufficient room for bolt tightening on the inside of the column. For a 1-inch bolt diameter and a 1.75-inch minimum edge distance to a sheared edge, the minimum angle length is 9 inches. Per ASCE TC, the minimum area of the outstanding angle leg should be:

$$A_{samin} = 1.33 \times F_{yrd} \times A_{rb} / F_{ya} = 5.497 \text{ in}^2$$

A 5/8-inch thick angle with the 9-inch angle length results in A_{sa} equal to 5.625 in^2 .

The outstanding angle dimension is controlled by the number of bolts attaching the angle to the beam flange. As previously discussed, a minimum 8-inch dimension is desired here to allow room for four 1-inch-diameter bolts.

The vertical angle dimension has to be sufficient both to allow room for bolts to the column flange and to permit yielding when the seat angle is in tension. The ductility of the connection, when in positive bending, is derived from angle hinging, as shown in Figure 9.2-8.

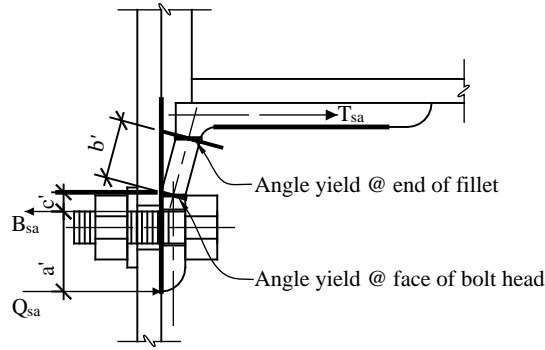

Figure 9.2-8 Typical angle tension hinging mechanism

This mechanism is based on research by Arum (1996). The following equations can be used to determine the associated angle tension, prying forces, and bolt forces associated with the angle hinging mechanism.

$$a' = L_{vsa} - g_{sa} + d_{bsa} / 2 = 2.500 \text{ in.}$$

$$c' = (W_{sa} - d_{bsa}) / 2 = 0.313 \text{ in.}$$

$$b' = L_{vsa} - a' - c' - k_{sa} = 2.062 \text{ in.}$$

$$M_{psa} = F_{ya} \times t_{sa}^2 \times L_{sa} / 4 = 31.641 \text{ kip-in}$$

$$T_{sa} = 2 \times M_{psa} / b' = 30.682 \text{ kips}$$

$$Q_{sa} = M_{psa} / a' \times (1 + 2 \times c' / b') = 16.491 \text{ kips}$$

$$B_{sa} = T_{sa} + Q_{sa} = 47.173 \text{ kips}$$

The above equations were derived in the same fashion as the prying action equations currently given in Section 9 of the AISC Manual with the same limitations applied to a' . The nomenclature in the above equations is shown in Figure 9.2-9.

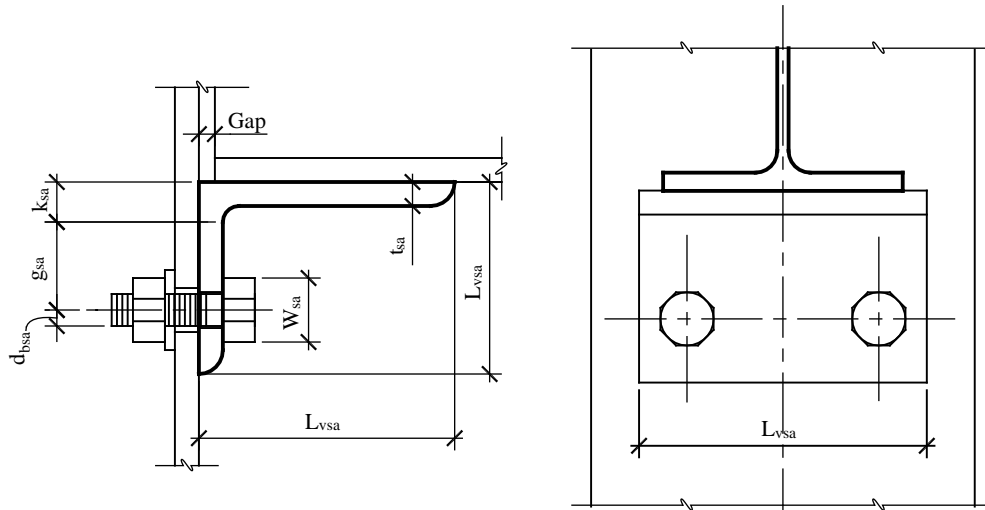

Figure 9.2-9 Seat angle nomenclature

The author recommends that the ratio of t_{sa}/b' be limited to no more than 0.5, so that the angle can properly develop the assumed hinges. For the example detail, the ratio is 0.303.

9.2.3.5 Bolts in Vertical Seat Angle Leg. The bolts in the vertical seat angle leg are designed primarily to resist tension in the case of connection positive moment. To protect against premature tension failure, the bolt force calculated in the previous section should be magnified by R_y from AISC 341 Table I-6-1.

$$R_y \times B_{sa} = 1.5 \times 47.173 \text{ kips} = 70.76 \text{ kips}$$

The tension capacity for two 1-inch-diameter A490 bolts is 133 kips.

9.2.3.6 Bolts in Outstanding Seat Angle Leg. The bolts in the outstanding leg of the seat angle must be designed for the shear transfer between the beam flange and the seat angle. For positive moments, this force is limited by tension hinging of the seat angle as calculated previously. For negative moments, this force is the sum of tension from the reinforcing steel and tension developed from hinging of the web angles. In general, the later will be significantly more than the former. The tension hinging capacity of the web angles, T_{wa} is calculated in the same way as the tension hinging of the seat angle. Again, to protect against premature shear failure of bolts, the tension capacity of the web angle and the reinforcing steel is magnified by an appropriate R_y . ASCE TC recommends $R_y = 1.25$ for the reinforcing steel.

$$R_y \times T_{wa} + R_y \times F_{yrd} \times A_{rb} = 1.5 \times 22.5 \text{ kips} + 1.25 \times 60 \text{ ksi} \times 2.48 \text{ in}^2 = 220 \text{ kips}$$

The published shear capacity for four 1-inch-diameter A490-X bolts is 177 kips; however, this capacity includes a 0.8 reduction to account for joint lengths up to 50 inches per the RCSC. The RCSC further states that this reduction does not apply in cases where the distribution of force is essentially uniform along the joint. When one increases the published shear capacity by $1/0.8$, the revised shear capacity is 221 kips. Bolt bearing at the beam flange and at the seat angle should also be checked.

9.2.3.7 Double Angle Web Connection. The primary purpose of the double angle web connection is to resist shear. Therefore, it can be selected directly from the AISC Manual; the specific design limits will not be addressed here. The required shear force is determined by adding the seismic demand to the

gravity demand. The seismic demand for the W21x44 PRCC is the sum of the positive and negative moment capacity (607 kip-ft) divided by the appropriate beam length. For the typical 25-foot beam length, the seismic shear is approximately 25 kips.

9.3 LOADS AND LOAD COMBINATIONS

9.3.1 Gravity Loads and Seismic Weight

The design gravity loads and the associated seismic weights for the example building are summarized in Table 9.3-1. The seismic weight of the storage live load is taken as 50 percent of the design gravity load (a minimum of 25 percent is required by *Standard* Section 12.7.2). To simplify this design example, the roof design is assumed to be the same as the floor design, and floor loads are used rather than considering special roof and snow loads.

Table 9.3-1 Gravity Load and Seismic Weight

	Gravity Load	Seismic Weight
Non-Composite Dead Loads (D_{nc})		
4.5-in. Slab on 0.6-in. Form Deck (4.5-in. total thickness) plus Concrete Ponding	58 psf	58 psf
Joist and Beam Framing	6 psf	6 psf
Columns	2 psf	2 psf
Total:	66 psf	66 psf
Composite Dead Loads (D_c)		
Fire Insulation	4 psf	4 psf
Mechanical and Electrical	6 psf	6 psf
Ceiling	2 psf	2 psf
Total:	12 psf	12 psf
Precast Cladding System	800 plf	800 plf
Live Loads (L)		
Typical Area Live and Partitions (Reducible)	70 psf	10 psf
Records Storage Area Live (Non-Reducible)	200 psf	100 psf

The reason for categorizing dead loads as non-composite and composite is explained in Section 9.4.2.

Live loads are applied to beams in the analytical model, with corresponding live load reductions appropriate for beam design. Column live loads are adjusted to account for different live load reduction factors, including the 20 percent reduction on storage loads for columns supporting two or more floors per *Standard* Section 4.8.2.

9.3.2 Seismic Loads

The basic seismic design parameters are summarized in Table 9.3-2

Table 9.3-2 Seismic Design Parameters

Parameter	Value
S_s	0.20
S_I	0.06
Site Class	E
F_a	2.5
F_v	3.5
$S_{MS} = F_a S_s$	0.50
$S_{MI} = F_v S_I$	0.21
$S_{DS} = 2/3 S_{MS}$	0.33
$S_{DI} = 2/3 S_{MI}$	0.14
Occupancy Category	II
Importance Factor	1.0
Seismic Design Category (SDC)	C
Frame Type per <i>Standard</i> Table 12.2-1	Composite Partially Restrained Moment Frame
R	6
Ω_0	3
C_d	5.5

For Seismic Design Category C, the height limit is 160 feet, so the selected system is permitted for this 52-foot-tall example building. The building is regular in both plan and elevation; consequently, the Equivalent Lateral Force Procedure of Section 12.8 is permitted in accordance with *Standard* Table 12.6-1. The seismic weight, W , totals 7,978 kips. The approximate period is determined to be 0.66 seconds using Equation 12.8-7 and the steel moment-resisting frame parameters of Table 12.8-2. The coefficient for upper limit on calculated period, C_u , from Table 12.8-1 is 1.62, resulting in T_{max} of 1.07 seconds for purposes of determining strength-level seismic forces.

A specific value for PRCC stiffness must be selected in order to conduct a dynamic analysis to determine the building period. It is recommended that the designer use K_{ci} of the negative moment-rotation behavior given in Section 9.2.2 above for this analysis. This should result in the shortest possible analytical building period and thus the largest seismic design forces. For the example building, the computed periods of vibration in the first modes are 2.13 and 1.95 seconds in the north-south and east-west directions, respectively. These values exceed T_{max} , so strength-level seismic forces must be computed using T_{max} for the period. The seismic response coefficient is then given by:

$$C_s = \frac{S_{DI}}{T\left(\frac{R}{I}\right)} = \frac{0.14}{1.07\left(\frac{6}{1.0}\right)} = 0.022$$

The total seismic forces or base shear is then calculated as:

$$V = C_s W = (0.022)(7,978) = 174 \text{ kips} \quad (\text{Standard Eq. 12.8-1})$$

The distribution of the base shear to each floor (by methods similar to those used elsewhere in this volume of design examples) is:

Roof (Level 4):	77 kips
Story 4 (Level 3):	53 kips
Story 3 (Level 2):	31 kips
<u>Story 2 (Level 1):</u>	<u>13 kips</u>
Σ :	174 kips

For Seismic Design Category C, the value of ρ is permitted to be taken as 1.0 per *Standard* Section 12.3.4.1, so the above story shears are applied as E_h without any additional magnification.

9.3.3 Wind Loads

From calculations not illustrated here, the gross service-level wind force following ASCE 7 is 83 kips (assuming 90 mph, 3-second-gust wind speed). Including the directionality effect and the strength load factor, the design wind force is less than the design seismic base shear. The wind force is not distributed in the same fashion as the seismic force, thus the story shears and the overturning moments for wind are considerably less than for seismic. The distribution of the wind base shear to each floor is:

Roof (Level 4):	13 kips
Story 4 (Level 3):	25 kips
Story 3 (Level 2):	23 kips
<u>Story 2 (Level 1):</u>	<u>22 kips</u>
Σ :	83 kips

Because the wind loads are substantially below the seismic loads, they are not considered in subsequent strength design calculations; however, wind drift is considered in the design.

9.3.4 Notional Loads

AISC 360 now requires that notional loads be included in the building analysis. As shown later, the example building qualifies for application of notional loads to gravity-only load combinations. The notional load at level i is $N_i = 0.002Y_i$, where Y_i is the gravity load applied at level i . For our example building, these values are as follows:

$$ND_{nc} = 4,258 \text{ kips} \times 0.002 = 8.516 \text{ kips} / 4 \text{ floors} = 2.13 \text{ kips/floor}$$

$$ND_c = 2,393 \text{ kips} \times 0.002 = 4.786 \text{ kips} / 4 \text{ floors} = 1.20 \text{ kips/floor}$$

$$NL = 4,469 \text{ kips} \times 0.002 = 8.938 \text{ kips} / 4 \text{ floors} = 2.23 \text{ kips/floor}$$

The notional loads are applied in the same manner as the seismic and wind loads in each orthogonal direction of the building, and they are factored by the same load factors that are applied to their corresponding source (such as 1.2 or 1.4 for dead loads). It is important to note that, in general, notional loads should be determined, at a minimum, on a column-by-column basis rather than for an entire floor as done above. This will allow the design to capture the effect of gravity loads that are not symmetric about

the center of the building. The example building happens to have gravity loads that are concentric with the center of the building, so it does not matter in this case.

9.3.5 Load Combinations

Three load combinations (from *Standard* Section 2.3.2) are considered in this design example.

- Load Combination 2: $1.2D + 1.6L$
- Load Combination 5: $1.2D + 0.5L + 1.0E$
- Load Combination 7: $0.9D + 1.0E$

Expanding the combinations for vertical and horizontal earthquake effects, breaking D into D_{nc} and D_c (defined in Section 9.3.1), and including notional loads, results in:

- Load Combination 2: $1.2(D_{nc} + ND_{nc}) + 1.2(D_c + ND_c) + 1.6(L + NL)$
- Load Combination 5: $1.2D_{nc} + 1.2D_c + 0.5L + 1.0E_h + 1.0E_v$
 $E_v = 0.2S_{DS}(D_{nc} + D_c) = 0.2(0.33)(D_{nc} + D_c) = 0.067(D_{nc} + D_c)$
 $1.267D_{nc} + 1.267D_c + 0.5L + 1.0E_h$
- Load Combination 7: $0.9D_{nc} + 0.9D_c + 1.0E_h - 1.0E_v$
 $0.833D_{nc} + 0.833D_c + 1.0E_h$

D_{nc} has to be applied separately to the columns and beams because of the two-stage connection behavior (discussed later). D_{ncc} is for column loading, and D_{ncb} is for beam loading. This breakout of the loading results in the following combinations:

- Stage 1 Analysis:
 - Load Combinations 2 and 5: $1.2D_{ncb}$
 - Load Combination 7: $0.9D_{ncb}$
- Stage 2 Analysis:
 - Load Combination 2: $1.2(D_{ncc} + ND_{nc}) + 1.2(D_c + ND_c) + 1.6(L + NL)$
 - Load Combination 5: $1.2D_{ncc} + 0.067D_{ncb} + 1.267D_c + 0.5L + 1.0E_h$
 - Load Combination 7: $0.9D_{ncc} - 0.067D_{ncb} + 0.833D_c + 1.0E_h$

The columns are designed from the Stage 2 Analysis, and the beams are designed from the linear combination of the Stage 1 and Stage 2 Analyses.

Because partially restrained connection behavior is nonlinear, seismic and wind drift analyses must be carried out for each complete load combination, rather than for horizontal loads by themselves. Note that *Standard* Section 12.8.6.2 allows drifts to be checked using seismic loads based on the analytical building period.

- Seismic Drift: $1.0D_{ncc} + 0.067D_{ncb} + 1.0D_c + 0.5L + 1.0E_h$
- Wind Drift: $1.0D_{ncc} + 1.0D_c + 0.5L + 1.0W$

The typical permutations of the above combinations have to be generated for each orthogonal direction of the building; however, orthogonal effects need not be considered for Seismic Design Category C provided the structure does not have a horizontal structural irregularity (*Standard Sec. 12.5.3*).

9.4 DESIGN OF C-PRMF SYSTEM

9.4.1 Preliminary Design

The goal of an efficient partially restrained building design is to have a sufficient number of beams, columns, and connections participating in the lateral system so that the forces developed in any of these elements from lateral loads is relatively small compared to the gravity design. In other words, design for gravity as if the connections are pinned; add the connections, and check to see if any beams or columns must be upsized to handle the lateral loads. The author cautions designers against trying to reduce beam sizes below the initial gravity sizes unless a full inelastic, path-dependent analysis accounting for potential shakedown of the connections is conducted. At this time, such an analysis typically is relegated to academic study and is not applied in real building design. The analysis methods described below do not go to that level of detail.

Once the building has been designed for gravity, a preliminary lateral analysis can be made to assess whether the proposed steel framing sizes may be suitable for lateral loads in combination with gravity loads. Typically this is done assuming all the PRCCs are rigid connections. Two basic checks can be based on this preliminary analysis. First, review connection moments that come from the lateral load cases alone (earthquake moments and wind moments) without gravity. If these moments (at strength levels) exceed approximately 75 percent of the negative moment capacity of the PRCC then either additional beams, columns, and connections need to be added to the lateral system or existing beams need to be upsized to provide larger PRCCs with higher capacities. Second, perform a preliminary assessment of the building drift. While there is no simple, reliable relationship between rigid frame drift and C-PRMF drift, the author typically assumes that the partially restrained system will drift approximately twice as much as a fully rigid analysis indicates. Keep in mind that these preliminary checks are made to establish basic system proportions before extensive modeling efforts are made to include the real partially restrained behavior of the building.

Using this preliminary design method, initial floor framing was selected. In accordance with the ASCE TC, the beams are designed to be 100 percent composite; no partial composite design is used.

The W18x35 typical interior girder is determined from a simple beam design. This typical size would work for all locations with the exception of the girders that support storage load on both sides (Grids 4 and 5 between Grids C and D). For simplicity, the example design was not further refined. The W18x35 size would also work as the Grid Line A and F spandrel beams; however, a W21x44 spandrel beam is used to help control drift in the north-south direction and help equalize the building periods in both directions. Note that the W21x44 improves drift less because of the increase in moment of inertia than due to the increase in beam depth, which increases PRCC moment-rotation stiffness.

9.4.2 Application of Loading

PRCC do not develop substantial beam end restraint until after the concrete has hardened (since the reinforcing steel cannot be mobilized without the concrete). At the time of concrete casting, the bare steel

elements of the connection are all that are present to resist rotation at the beam ends. The degree of restraint provided by the bare steel connection varies depending on the details; however, for purposes of design, the connection stiffness prior to concrete hardening typically is assumed to be zero (a pinned beam end). Consequently, the connection actually has two stages of behavior that need to be accounted for in the analysis. These two stages are the pre-composite stage, when the connection is assumed to behave as a pin, and the post-composite stage, when the connection is assumed to have the full moment-rotation behavior determined in Section 9.2.2. In a building where the complete lateral system is provided by PRCCs, temporary bracing may be required to provide lateral stability prior to concrete hardening.

The above two-stage connection behavior requires resolution of dead load into portions consistent with each stage. This is why the dead loads in Section 9.3.1 are separated into D_{nc} and D_c . The D_{nc} load is placed on the beams during the Stage 1 analysis (when the connections are pins) but is not placed on the beams (other than the seismic fraction) during the Stage 2 analysis (when the connections have PRCC stiffness). In Stage 2 analysis, the D_{nc} loads are placed directly on the columns so that their destabilizing effects are accounted for properly in the nonlinear P-delta analysis. That is why D_{nc} loads are further broken down into D_{ncc} and D_{ncb} . The Stage 2 load combinations are presented graphically in Figures 9.4-1 and 9.4-2.

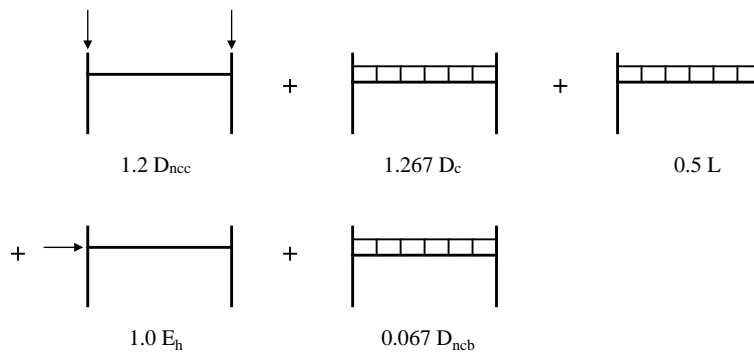

Figure 9.4-1 Stage 2 Load Combination 5

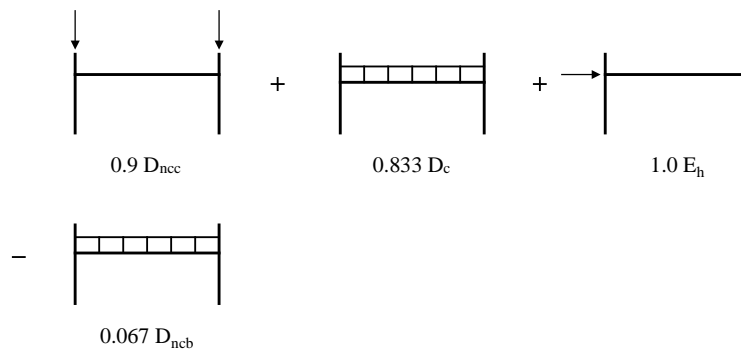

Figure 9.4-2 Stage 2 Load Combination 7

9.4.3 Beam and Column Moment of Inertia

ASCE TC recommends that the beam moment of inertia used for frame analysis be increased to account for the stiffening effect that the composite slab has on the beam moment of inertia. The use of the increased moment of inertia is also required by AISC 341 Part II Section 8.3. The following equivalent moment of inertia is recommended:

$$I_{eq} = 0.6I_{LB+} + 0.4I_{LB-} \quad (\text{Eq. 5, ASCE TC})$$

I_{LB+} and I_{LB-} are the lower bound moments of inertia in positive and negative bending, respectively. I_{LB+} can be determined from Table 3-20 in the AISC Manual as 1,594 in⁴ for the W18x35 interior girder and 1,570 in⁴ for the W21x44 spandrel beam once composite beam design values are known. Note that the W21x44 spandrel 100 percent composite design is limited by the effective slab capacity, which is why its composite moment of inertia is so close to that of the W18x35 interior girder. I_{LB-} can be assumed as the bare steel moment of inertia, as 510 in⁴ for the W18x35 interior girder and 843 in⁴ for the W21x44 spandrel beam. It is permitted to account for the transformed area of the reinforcing steel in calculating I_{LB-} , but the bare steel beam property has been used in this example. The equivalent moment of inertia is then calculated as:

- W18x35 Interior Girder: $I_{eq} = 0.6(1,594) + 0.4(510) = 1,160 \text{ in}^4$
- W21x44 Spandrel Beam: $I_{eq} = 0.6(1,570) + 0.4(843) = 1,279 \text{ in}^4$

The bare steel moment of inertia values in the building analysis are revised to these values, which are suitable for service-level limit state checks. Use of a 0.8 reduction factor on the beam moment of inertia is required by AISC 360 Section 7.3(3) for strength-level checks from direct analysis.

The bare steel moment of inertia for the columns is appropriate for service-level checks. For strength-level checks, the same 0.8 reduction factor on the moment of inertia used on beams would apply to the columns. A further reduction on the column moment of inertia for strength-level checks is required if P_r/P_y exceeds 0.5. A quick scan of the column loads from the building analysis results indicates that the only columns that exceed this value are the first-story columns at Grids C-4, C-5, D-4, and D-5 for Load Combination 2 only.

$$\tau_b = 4[P_r/P_y(1-P_r/P_y)] = 4[612 \text{ kips}/1130 \text{ kips} (1- 612 \text{ kips}/1130 \text{ kips})] = 0.99$$

In the author's judgment, the above reduction on so few columns will have little or no effect on the building analysis results, and it is ignored for this example.

9.4.4 Connection Behavior Modeling

For each connection type (such as W18 PRCC or W21 PRCC), there are four different connection behavior models used, as developed in Section 9.2.2. First, the connection is modeled as a linear spring with stiffness K_{ci} . This is done for the dynamic analysis of the building needed to determine the building period. Second, a service-level analysis is conducted using the full nonlinear service moment-rotation behavior. Third, a connection Stage 1 building analysis is done with the connections having no moment resistance (analytical pins) so the beam pre-composite loads can be applied. Finally, a Stage 2 building strength analysis under factored loads is performed with the full nonlinear moment-rotation behavior.

The multi-linear elastic link option provided in SAP2000 is used to model the connection springs for all stages. This nonlinear spring model allows user-defined behavior for two types of analysis, linear and

nonlinear, for each spring type. This is helpful to handle the various connection behaviors because the dynamic analysis and the Stage 1 pre-composite beam load analysis can both be linear analysis which automatically switches the connection spring to the defined linear behavior. Another important point is that this particular spring model stays on the defined connection curve in a nonlinear-elastic manner. That is, the analysis simply rides up and down always converging at moment-rotation points on the connection backbone curve. This allows what is known as a path independent analysis; the order of the loading does not matter. This is in contrast with a spring model with different connection unloading behavior, such as might be used to model the full hysteric connection behavior. If the connection unloading behavior is considered, the analysis is no longer path independent because the answer will depend on the sequence of loads that are applied. This path-dependent analysis is more accurate and allows consideration of connection shakedown to be captured in the model; however, it is also much more complicated when compared to the path-independent analysis. Since the simpler, path-independent connection modeling approach does not capture connection shakedown behavior, the author does not recommend reducing beam sizes from the pure simple pinned gravity design discussed in Section 9.4.1.

9.4.5 Building Drift and P-delta Checks

Drifts should be checked using the service moment-rotation curves along with the full moment of inertias for the beams and columns (no 0.8 reduction). Because of the nonlinear connection behavior, the analysis is nonlinear. Though optional, the author recommends including P-delta effects in the service drift checks for partially restrained building designs. Drifts are computed for the nonlinear load combinations developed in Section 9.3.5.

9.4.5.1 Torsional Irregularity Check. *Standard* Table 12.3-1 defines torsional irregularities. The story drift values at the each end of the example building are presented in Table 9.4-1. Since the ratio of maximum drift to average drift does not exceed 1.2, no torsional irregularity exists, accidental torsion need not be amplified, and drift may be checked at the center of the building (rather than at the corners).

Table 9.4-1 Torsional Irregularity Check

Story	North-south Direction (in.)						East-west Direction (in.)					
	Displacement		Story Drift				Displacement		Story Drift			
	A-1	F-1	A-1	F-1	avg	max/avg	F-1	F-8	F-1	F-8	avg	max/avg
1	0.40	0.45	0.40	0.45	0.43	1.06	0.31	0.37	0.31	0.37	0.34	1.08
2	0.91	1.03	0.51	0.58	0.55	1.06	0.72	0.84	0.41	0.47	0.44	1.07
3	1.32	1.49	0.41	0.46	0.43	1.06	1.05	1.22	0.33	0.38	0.35	1.08
4	1.55	1.76	0.23	0.27	0.25	1.06	1.23	1.44	0.19	0.22	0.20	1.08

9.4.5.2 Seismic Drift and P-delta Effect. The allowable seismic story drift is taken from *Standard* Table 12.12-1 as $0.025h_{sx} = (0.025)(13 \text{ ft} \times 12 \text{ in./ft}) = 3.9 \text{ in.}$ With C_d of 5.5 and I of 1.0, this corresponds to a story drift limit of 0.71 inch under the equivalent elastic forces (see *Standard* Section 12.8.6 for story drift determination). The story drifts with P-delta are presented in Table 9.4-2 below. Review of the drift values indicates that all drifts are within the 0.71-inch limit.

Table 9.4-2 Seismic Drift and P-delta Effect Checks

Story	North-south Direction (in.)						East-west Direction (in.)					
	Displacement		Story Drift				Displacement		Story Drift			
	w/o P-Δ	w/ P-Δ	w/o P-Δ	w/ P-Δ	$P\Delta_{amp}$	θ	w/o P-Δ	w/ P-Δ	w/o P-Δ	w/ P-Δ	$P\Delta_{amp}$	θ
1	0.38	0.43	0.38	0.43	1.14	0.12	0.30	0.34	0.30	0.34	1.12	0.10
2	0.86	0.97	0.48	0.55	1.14	0.12	0.70	0.78	0.40	0.44	1.12	0.10
3	1.25	1.41	0.39	0.43	1.10	0.09	1.02	1.13	0.32	0.35	1.09	0.08
4	1.48	1.66	0.24	0.25	1.06	0.06	1.22	1.33	0.19	0.20	1.05	0.04

Separate analyses are conducted to determine seismic drifts with and without P-delta effects. Due to the nonlinear connection behavior, all of the analyses are nonlinear. The ratio of these two drifts ($P\Delta_{amp}$) is compared to the 1.5 limit for ratio of second-order drift to first-order drift set forth in AISC 360 Section 7.3(2). Because the ratios are all below the 1.5 limit, it is permissible to apply the notional loads as a minimum lateral load for the gravity-only combination and not in combination with other lateral loads.

Provisions Section 12.8.7 now defines the stability coefficient (θ) as follows:

$$\theta = \frac{P_x \Delta I}{V_x h_{sx} C_d}$$

The story drift (Δ) is defined in *Standard* Section 12.8.6 as:

$$\Delta = \frac{C_d \delta_{xe}}{I}$$

Replacing Δ in the stability coefficient equation results in:

$$\theta = \frac{P_x \delta_{xe}}{V_x h_{sx}}$$

This value of θ can also be calculated from the P-delta amplifier presented in Table 9.4-2 by the following:

$$\theta = 1 - \frac{1}{P\Delta_{amp}}$$

The stability coefficients presented in Table 9.4-2 were calculated in this manner. Review of the values shows that θ varies from 0.04 to 0.12. *Provisions* Section 12.8.7 now requires that θ not exceed 0.10 unless the building satisfies certain criteria when subjected to either nonlinear static (pushover) analysis or nonlinear response history analysis. Because θ for the building in the north-south direction exceeds 0.10 in the lower stories, the designer would have to either increase the building stiffness in that direction or conduct an approved nonlinear analysis. Such nonlinear analysis is beyond the scope of this example.

9.4.5.3 Wind Drift. A wind drift limit of $h_{sx}/400$ was chosen based on typical office practice for this type of building. This gives a story drift limit of $13 \times 12 / 400 = 0.39$ inch. The wind drift values presented in Table 9.4-3 were determined for the 50-year return interval wind loads previously determined in Section 9.3.3 above. Review of the drift values indicates that all drifts are within the 0.39-inch limit.

Table 9.4-3 Wind Drift Results

Story	North-south Direction (in.)		East-west Direction (in.)	
	Displacement	Story Drift	Displacement	Story Drift
1	0.19	0.19	0.15	0.15
2	0.39	0.20	0.32	0.17
3	0.52	0.13	0.42	0.11
4	0.57	0.05	0.47	0.04

9.4.6 Beam Design

AISC 341 Part II Section 8.3 requires that composite beams be designed in accordance with AISC 360 Chapter I. The beams are designed for 100 percent composite action, and sufficient shear studs to develop 100 percent composite action are provided between the end and midspan. They do not develop 100 percent composite action between the column and the inflection point, but it may be easily demonstrated that they are more than capable of developing the full force in the reinforcing steel within that distance. Composite beam design is not unique to this example; however, composite beams acting as part of the lateral load-resisting system is unique and deserves further attention.

As a result of connection restraint, negative moments will develop at beam ends. These moments must be considered when checking beam strength. The inflection point cannot be counted on as a brace point, so it may be necessary to consider the full beam length as unbraced for checking lateral-torsional buckling and comparing that capacity to the negative end moments. Note that there are C_b equations in the literature that do a better job (as compared to the standard C_b equation in AISC 360) of predicting the lateral-torsional buckling strength of beams that are continuously attached to a composite slab floor system.

AISC 341 Part II Section 8 does not specifically address compactness criteria for beams; however, given that the beams are not being required to develop M_p , other than possibly under gravity loads, it is unlikely they would need to be seismically compact. The author recommends that they meet the compactness criteria of AISC 360. A quick check in Table 1-1 of the AISC Manual indicates that both W18x35 and W21x44 are compact for flexure.

9.4.7 Column Design

Requirements for column design are found in AISC 341 and AISC 360. AISC 341 Part II Section 8.2 requires that columns meet the requirements of AISC 341 Part I Sections 6 and 8. W10 columns of A992 steel meet all Section 6 material requirements.

AISC 341 Part I Section 8.3 requires a special load combination if $P_u/\phi_c P_n$ exceeds 0.4 for a column in a seismic load combination. The only columns that exceed this limit are the interior columns on Grid Lines C and D under the storage load. Because they are so close to the center of the building, the seismic

axial force in these columns is very small. Consequently, including the overstrength factor of 3.0 on the seismic axial portion of the column load will not have a meaningful effect on the column loads and can be ignored in this example.

The nominal strength of the columns is determined using $K = 1.0$ in accordance with AISC 360 Section 7.1. The associated column strength unity checks are presented in Table 9.4-4. The unity checks presented are for the first story of the center four columns in the building.

Table 9.4-4 Column Strength Check for W10x77

	Seismic Load Combination	Gravity Load Combination
Axial force, P_u	370 kip	612 kip
Moment, M_u	55 ft-kip	35 ft-kip
Interaction	0.606	0.866

Part II Section 8 does not specifically address the required compactness criteria; however, given the high R value for the lateral load-resisting system, the author has assumed that the columns would need to meet the seismically compact criteria given in Part I Table I-9-1. A W10x77 column from the lower level of an interior bay with storage load is illustrated (the axial load from the seismic load combination is used):

- Column Flange:

$$\lambda_{ps} = 0.3 \sqrt{\frac{E}{F_y}} = 0.3 \sqrt{\frac{29,000}{50}} = 7.22$$

$$\frac{b_f}{2t_f} = 5.86 \text{ (AISC Manual)} < 7.22$$

- Column Web:

$$C_a = \frac{P_u}{\phi_b P_y} = \frac{370 \text{ kips}}{0.9(50)22.6} = 0.364 > 0.125$$

$$\lambda_{ps} = 1.12 \sqrt{\frac{E}{F_y}} (2.33 - C_a) \geq 1.49 \sqrt{\frac{E}{F_y}}$$

$$\lambda_{ps} = 1.12 \sqrt{\frac{29,000}{50}} (2.33 - 0.364) = 53.03 \geq 1.49 \sqrt{\frac{29,000}{50}} = 35.88$$

$$\frac{h}{t_w} = 14.8 \text{ (AISC Manual)} < 53.03$$

As an alternative to calculating the compactness criteria by hand, the designer can use the AISC SDM Table 1-2. A quick review of this table indicates that the W10x77 is compact for flexure (beam) and for

axial loads (column). The dash in the table indicates that applied axial loads as large as P_y still result in the column meeting the seismically compact criteria.

The equivalent of the weak-beam–strong-column concept for the C-PRMF lateral system is a weak connection–strong column. This is not specifically addressed in AISC 341; however, ASCE TC recommends the following check:

$$\sum M_{p,col} \left(1 - \frac{P_u}{P_y} \right) \geq 1.25 (M_{cu}^- + M_{cu}^+)$$

For the same lower level interior W10x77 one gets:

$$2 \times 50 \times 97.6 \left(1 - \frac{370 \text{ kips}}{50 \times 22.6} \right) = 547 \text{ ft-kips} \geq 1.25 (232 + 151) = 479 \text{ ft-kips}$$

9.4.8 Connection Design

There is really little to do with the connection design at this stage because the full nonlinear connection behavior is being used in the analysis. This means that the connection moments will never exceed the connection capacity during the analysis. This is in contrast to any analysis method that models the connections with linear behavior. When the connections are modeled with linear behavior, it is up to the designer to confirm that the final connection results are consistent with the expected connection behavior. This might be very easy for building designs where connection moments are small; however, when the connections are being pushed close to their capacity, that sort of independent connection check by the designer can be problematic.

Although not entirely necessary, it is useful to check where the connections are along the expected behavior curves for any given analysis so one can see just how hard the connections are being pushed. The connection moment demand versus design capacities (including ϕ) are presented in Table 9.4-5. The demand values are from different load combinations. A quick check of this table indicates that this building design is not being pushed particularly hard and that there is likely significant reserve capacity in the lateral system.

Table 9.4-5 Connection Moment Demand vs. Capacity (kip-ft)

	W21 PRCC		W18 PRCC	
	(-) M- θ	(+) M- θ	(-) M- θ	(+) M- θ
Demand	136	87.0	126	37.0
Capacity	312	204	197	128
Ratio	0.44	0.43	0.64	0.29

9.4.9 Column Splices

Column splice design would be in accordance with AISC 341 Part I Section 8.4 but is not illustrated in this example.

9.4.10 Column Base Design

Column base design would be in accordance with AISC 341 Part I Section 8.5 but is not illustrated in this example.